

Owner: Komproment
No.: MD-21020-EN
Issued: 28-06-2021
Revised: 20-08-2024
Valid to: 28-06-2026

3rd PARTY VERIFIED

EPD

VERIFIED ENVIRONMENTAL PRODUCT DECLARATION | ISO 14025 & EN 15804



Owner of declaration
KOMPROMENT
Jellingvej 11
9230 Svenstrup
[DK25043499]



Issued:
28-06-2021

Valid to:
28-06-2026

Programme
EPD Danmark
www.epddanmark.dk



- Industry EPD
- Product EPD

Basis of calculation

This EPD is developed in accordance with the European standard EN 15804+A2.

Comparability

EPDs of construction products may not be comparable if they do not comply with the requirements in EN 15804. EPD data may not be comparable if the datasets used are not developed in accordance with EN 15804 and if the background systems are not based on the same database.

Validity

This EPD has been verified in accordance with ISO 14025 and is valid for 5 years from the date of issue.

Use

The intended use of an EPD is to communicate scientifically based environmental information for construction products, for the purpose of assessing the environmental performance of buildings.

Declared product(s)

This EPD covers two shapes of tiles:

- Pantheon Nordic
- Colosseum Nordic

Each of these two shapes comes in seven different colours: Peat black, Beach Yellow, Nordic Red, Terracotta Red, Brazilian Brown, Cloudy Gray and Concrete Gray.

It was possible to group some of the colors into product groups, thus the declared types product variations are:

1. Product 1 (Peat Black)
2. Group 1 (Beach Yellow, Nordic Red, Terracotta Red)
3. Group 2 (Brazilian Brown, Cloudy Gray, Concrete Gray)

EPD type

- Cradle-to-gate with modules C1-C4 and D
- Cradle-to-gate with options, modules C1-C4 and D
- Cradle-to-grave and module D
- Cradle-to-gate
- Cradle-to-gate with options

Production site

Via Tolomei 61, 35010 Loreggia, Italy

Product use

Façade / Roof

Declared/ functional unit

1 tonne of clay tiles Pantheon Nordic and Colosseum Nordic for with an expected average reference service life of 150 years.

Year of data

2019

EPD version

2. version. Updated logo.

CEN standard EN 15804 serves as the core PCR
Independent verification of the declaration and data, according to EN ISO 14025
<input type="checkbox"/> internal <input checked="" type="checkbox"/> external
Third party verifier:
Charlotte Merlin

Henrik Fred Larsen
EPD Danmark

Life cycle stages and modules (MND = module not declared)

Product			Construction process		Use								End of life				Beyond the system boundary
Raw material supply	Transport	Manufacturing	Transport	Installation process	Use	Maintenance	Repair	Replacement	Refurbishment	Operational energy use	Operational water use	De-construction demolition	Transport	Waste processing	Disposal	Re-use, recovery and recycling potential	
A1	A2	A3	A4	A5	B1	B2	B3	B4	B5	B6	B7	C1	C2	C3	C4	D	
X	X	X	MND	MND	MND	MND	MND	MND	MND	MND	MND	X	X	X	X	X	

Product information

Product description

This EPD contains two façade tiles (Colosseum Nordic and Pantheon Nordic) in 7 different colours. Both tiles are produced in Italy and consist of mainly clay, sand and water extracted in Italy. To achieve the different colors some of the tiles are added engobe finish and emmenore. Engobe consist of clay and water and emmenore is 100% braunite, modelled as manganese dioxide as the best available data representation. The main product components are shown in the table below.

Material	Weight-% of declared product
Terracotta clay, virgin material	77-81
Terracotta clay, secondary material	10-11
Dry clay powder	0-0.29
Sand	3.6-10
Emmenore (braunite)	0-8.5
Engobe (clay)	0-0.29
TOTAL	100

Water is also added in the production of clay tiles, but evaporates completely during the manufacturing, thus not included in this material table.

Material	Weight-% of packaging
Plastic wrap	1
EU pallet	99
TOTAL	100

Representativity

This declaration, including data collection, the modelled foreground system and the results, represents 1 tonne of clay products from the production sites located in Loreggia, Italy. Product specific data are based on average values collected from 2019.

Background data are based on the GaBi database 2020, supplemented with a few datasets from Ecoinvent 3.6. Generally, the used generic

background datasets are of high quality and less than 10 years old. In some cases, older data has been used to avoid data gaps.

This EPD represent an EoL scenario for a Danish market.

Hazardous substances

The products does not contain substances listed in the "Candidate List of Substances of Very High Concern for authorisation" with a content exceeding 0.1% weight-%:

(<http://echa.europa.eu/candidate-list-table>)

Absences of these substances is declared by the producer, Komproment.

Essential characteristics (CE)

The clay products are covered by harmonized technical specification EN 1304. Declaration of performance according to EU regulation 305/2011 is available for all declared product variations.

Further technical information can be obtained by contacting the manufacturer or on the manufacturer's website:

www.komproment.com

Reference Service Life (RSL)

150 years (in accordance with the PCR document issued by the European Brick and Tile Industry Association /TBE/):

"For clay construction products, the RSL is 150 years. Studies have shown that clay construction products stand out with their high durability and prevail with no maintenance and a life span of 150 years and more".

Picture of product(s)

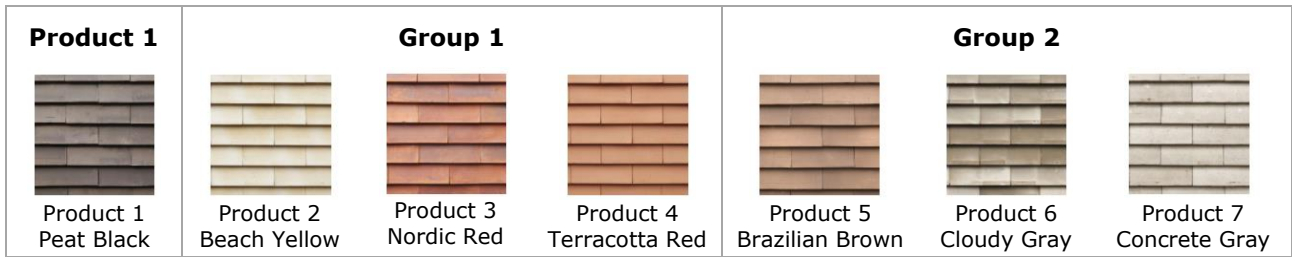

LCA background

Declared unit/functional unit

The LCI and LCIA results in this EPD relates to 1 tonne of clay tiles (Pantheon Nordic and Colosseum Nordic) with an expected average reference service life of 150 years in accordance with the TBE PCR for clay products for use in Denmark.

To cover 1 m² of façade/roof 12.12 pieces of tiles are needed with a dry weight of 3.85 kg/piece for Pantheon Nordic and 3.55 kg/piece for Colosseum Nordic.

Name	Value	Unit
Declared unit	1	
Density	1600	kg/m ³
Conversion factor to 1 kg.	0.001	-
Area for coverage (Pantheon Nordic)	21.4	m ² /1 ton
Area for coverage (Colosseum Nordic)	23.2	m ² /1 ton

PCR

This EPD is developed according to the core rules for the product category of construction products in EN15804+A2:2019 and the product specific PCR "TBE PCR for clay construction products" (2020).

Flowdiagram

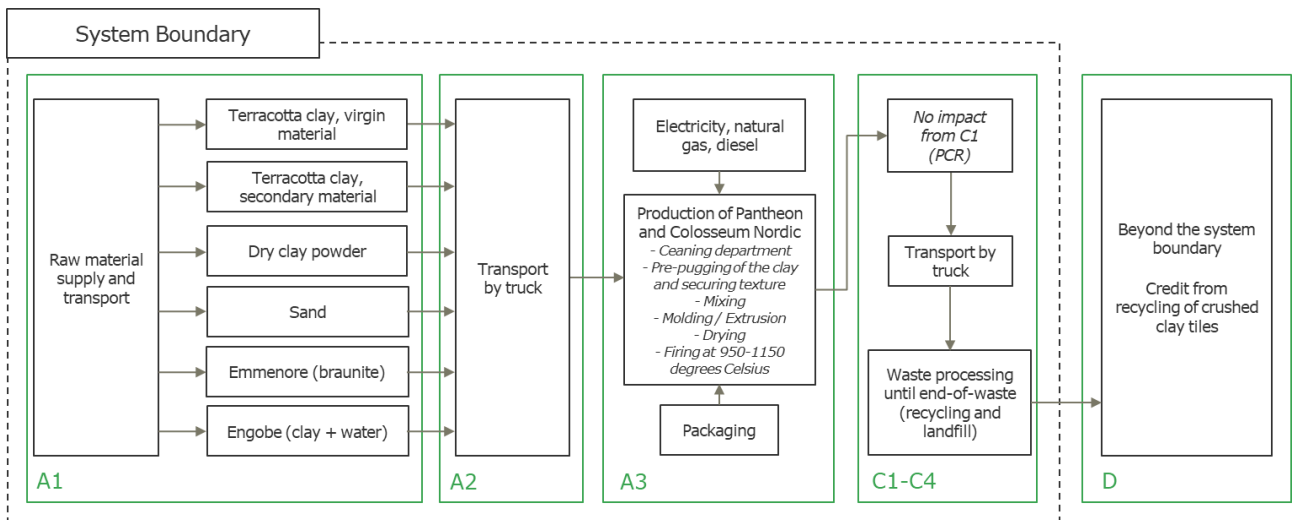

System boundary

This EPD is based on a “cradle to gate with modules C1-4 and module D” LCA, in which 100 weight-% has been accounted for. The production of 1 tonne of clay tiles includes a waste of 4% in the manufacturing process.

The general rules for the exclusion of inputs and outputs follows the requirements in EN 15804+A2, 6.3.5, where the total of neglected input flows per module shall be a maximum of 5 % of energy usage and mass and 1 % of energy usage and mass for unit processes.

Product stage (A1-A3) includes:

- A1 – Extraction and processing of raw materials
- A2 – Transport to the production site
- A3 – Manufacturing processes

The product stage comprises the acquisition of all raw materials, products and energy, transport to the production site, packaging and waste processing up to the “end-of-waste” state or final disposal. The LCA results are declared in aggregated form for the product stage, which means, that the sub-modules A1, A2 and A3 are declared as one module A1-A3.

Production of Komproment façade tiles:

Clay and other minerals are extracted from earth using mining equipment powered by diesel. The clay is then transported to a storage at the production facility. Preparing the clay for tile production consists of removing stones and impurities as well as pre-pugging the clay to secure texture. Next, the blend of ingredients desired is sent on to the tile shaping processes (extrusion). The extruded tile is created by forcing a mixture of clay and water into a die, then cutting the resulting column into shorter units with wires. Once the bricks are formed, they are dried to remove excess moisture with heat recovered from the firing process. The bricks are fired with natural gas in a tunnel kiln and then cooled. Finally, they are destacked – automatically stacked on EU pallets (wood) and wrapped in very thin plastic film (polyethylene) to hold them together and prevent accidents during transport and in the yard.

Packaging material:

The tiles are packaged on a wooden EU pallet, which is assumed reused 10 times and the modelling has been done accordingly with only 10% virgin material input and 90% secondary material input.

End of Life (C1-C4) includes:

- C1 - de-construction, demolition
- C2 - transport to waste processing
- C3 - waste processing for reuse, recovery and/or recycling
- C4 – disposal

C1 can be ignored according to the PCR, whereas the rest of the modules are included using national scenarios over predefined end of life scenarios from the PCR. A Danish waste scenario is used to represent the Danish marked used in this LCA study.

In C2 transport distances to waste processes according to the PCR has been applied in the GaBi model.

In C3-C4 3% of the bricks are landfilled (C4) and 97% are recycled (C3) in Denmark. For the recycling the bricks are crushed into smaller pieces and used as gravel for pathways (Miljøstyrelsen, 2003).

Re-use, recovery and recycling potential (D) includes:

Module D includes the reuse, recovery and/or recycling potentials, expressed as net impacts and benefits. This includes the substitution of gravel from the recycling of crushed bricks. According to EN15804+A2 section 6.4.3.3, the benefit potential in module D is calculated from the net output flow. Thus, it is only the primary material content in the tiles that are calculated as recycled with a substitution of gravel. This excludes the amount of secondary material input, which is the clay from the public excavation (12% of the total terracotta clay input). As there was no available information on the mix of primary and secondary material input for gravel used for pathways in Denmark, a conservative assumption was made to model only 50% of the amount of bricks recycled as gravel in module D.

Because A4-A5 is not declared in this EPD energy recovery from incineration of packaging material is not included in the module D.

Note

It should be noted that the uptake of the biogenic carbon from the packaging material (EU pallet of wood) in module A3 is usually released again in module A5, but module A5 is not declared in this EPD. The uptake of biogenic carbon in A3 from the packaging material is very small in relation to the total climate change indicator for A1-3, and there is only included an uptake of biogenic carbon from the 10% virgin wood material .

Furthermore, the grouping of product into product groups (Group 1 and Group 2) was possible because the variation of the results between the products in the groups vary less than +/- 10% in accordance with the General Programme Instruction for EPD Denmark. It is only the modules A1-A3 and D that has a variation between the products, whereas modules C1-C4 is the same across the products. The difference in module D is due to different input of

terracotta clay, hence the amount of secondary material.

It should be noticed that a few impact indicators varied more than +10% between the single products (between highest and lowest impact) within both Group 1 and Group 2. For these indicators the results have been declared in Group 1 and Group 2 from the product with the highest impact as a worst case, whereas it is the average of the environmental impacts for the products in each group that is declared for the rest of the indicators. It should be noticed that the indicators with a variation larger than +/- 10% is not the main environmental impact indicators, but from the resource use indicators.

The emmenore (braunite) is modelled 1:1 with manganese dioxide from the Ecoinvent 3.6 database. This dataset was the best available data to represent braunite (both manganese dioxide and braunite are referred to as manganese oxides and are used as pigment in clay production). This is a conservative assumption that may be an overestimation of the braunite, thus it contains an uncertainty.

LCA results

Product 1: Peat Black

ENVIRONMENTAL IMPACTS PER 1 TONNE OF FAÇADE TILE							
Parameter	Unit	A1-A3	C1	C2	C3	C4	D
GWP-total	[kg CO ₂ eq.]	4.61E+02	0.00E+00	4.75E+00	2.34E-01	4.20E-01	-9.05E-01
GWP-fossil	[kg CO ₂ eq.]	4.63E+02	0.00E+00	4.66E+00	2.36E-01	4.55E-01	-9.33E-01
GWP-biogenic	[kg CO ₂ eq.]	-2.15E+00	0.00E+00	5.07E-02	-2.40E-03	-3.61E-02	3.22E-02
GWP-luluc	[kg CO ₂ eq.]	7.24E-01	0.00E+00	3.82E-02	4.48E-04	1.31E-03	-4.47E-03
ODP	[kg CFC 11 eq.]	1.86E-05	0.00E+00	8.66E-16	1.05E-09	1.69E-15	-8.28E-15
AP	[mol H ⁺ eq.]	1.86E+00	0.00E+00	5.45E-03	3.94E-04	3.26E-03	-6.45E-03
EP-freshwater	[kg PO ₄ eq.]	1.24E-01	0.00E+00	1.44E-05	6.93E-06	7.81E-07	-3.92E-06
EP-marine	[kg N eq.]	3.14E-01	0.00E+00	1.68E-03	1.21E-04	8.40E-04	-2.54E-03
EP-terrestrial	[mol N eq.]	3.40E+00	0.00E+00	1.99E-02	1.22E-03	9.23E-03	-2.80E-02
POCP	[kg NMVOC eq.]	9.31E-01	0.00E+00	4.52E-03	3.38E-04	2.54E-03	-7.31E-03
ADPm ¹	[kg Sb eq.]	2.70E-02	0.00E+00	3.82E-07	2.40E-07	4.09E-08	-1.59E-07
ADPf ¹	[MJ]	7.04E+03	0.00E+00	6.30E+01	2.68E+00	5.97E+00	-1.37E+01
WDP ¹	[m ³]	2.96E+02	0.00E+00	4.60E-02	1.69E-02	4.77E-02	-1.03E-01
Caption	GWP-total = Global Warming Potential - total; GWP-fossil = Global Warming Potential - fossil fuels; GWP-biogenic = Global Warming Potential - biogenic; GWP-luluc = Global Warming Potential - land use and land use change; ODP = Ozone Depletion; AP = Acidification; EP-freshwater = Eutrophication – aquatic freshwater; EP-marine = Eutrophication – aquatic marine; EP-terrestrial = Eutrophication – terrestrial; POCP = Photochemical zone formation; ADPm = Abiotic Depletion Potential – minerals and metals; ADPf = Abiotic Depletion Potential – fossil fuels; WDP = water use						
Disclaimer	¹ The results of this environmental indicator shall be used with care as the uncertainties on these results are high or as there is limited experienced with the indicator.						

ADDITIONAL ENVIRONMENTAL IMPACTS PER 1 TONNE OF FAÇADE TILE							
Parameter	Unit	A1-A3	C1	C2	C3	C4	D
PM	[Disease incidence]	1.21E-05	0.00E+00	3.62E-08	4.33E-09	4.04E-08	-3.09E-07
IRP ²	[kBq U235 eq.]	5.91E+01	0.00E+00	1.72E-02	1.51E-02	6.97E-03	-1.49E-01
ETP-fw ¹	[CTUe]	2.23E+04	0.00E+00	4.71E+01	1.23E+00	3.41E+00	-7.64E+00
HTP-c ¹	[CTUh]	1.57E-07	0.00E+00	9.74E-10	1.89E-10	5.05E-10	-5.66E-10
HTP-nc ¹	[CTUh]	6.73E-06	0.00E+00	4.97E-08	4.09E-09	5.57E-08	-5.77E-08
SQP ¹	-	2.94E+03	0.00E+00	2.21E+01	2.76E+00	1.24E+00	-3.75E+00
Caption	PM = Particulate Matter emissions; IRP = Ionizing radiation – human health; ETP-fw = Eco toxicity – freshwater; HTP-c = Human toxicity – cancer effects; HTP-nc = Human toxicity – non cancer effects; SQP = Soil Quality (dimensionless)						
Disclaimers	¹ The results of this environmental indicator shall be used with care as the uncertainties on these results are high or as there is limited experienced with the indicator.						
	² This impact category deals mainly with the eventual impact of low dose ionizing radiation on human health of the nuclear fuel cycle. It does not consider effects due to possible nuclear accidents, occupational exposure nor due to radioactive waste disposal in underground facilities. Potential ionizing radiation from the soil, from radon and from some construction materials is also not measured by this indicator.						

RESOURCE USE PER 1 TONNE OF FAÇADE TILE

Parameter	Unit	A1-A3	C1	C2	C3	C4	D
PERE	[MJ]	7.54E+02	0.00E+00	3.64E+00	3.78E+00	7.82E-01	-3.43E+00
PERM	[MJ]	4.80E+01	0.00E+00	0.00E+00	0.00E+00	0.00E+00	0.00E+00
PERT	[MJ]	8.02E+02	0.00E+00	3.64E+00	3.78E+00	7.82E-01	-3.43E+00
PENRE	[MJ]	7.02E+03	0.00E+00	6.32E+01	2.68E+00	5.97E+00	-1.37E+01
PENRM	[MJ]	1.34E+01	0.00E+00	0.00E+00	0.00E+00	0.00E+00	0.00E+00
PENRT	[MJ]	7.04E+03	0.00E+00	6.32E+01	2.68E+00	5.97E+00	-1.37E+01
SM	[kg]	1.37E+02	0.00E+00	0.00E+00	0.00E+00	0.00E+00	0.00E+00
RSF	[MJ]	0.00E+00	0.00E+00	0.00E+00	0.00E+00	0.00E+00	0.00E+00
NRSF	[MJ]	0.00E+00	0.00E+00	0.00E+00	0.00E+00	0.00E+00	0.00E+00
FW	[m ³]	7.11E+00	0.00E+00	4.24E-03	1.75E-03	1.51E-03	-4.22E-03
Caption	PERE = Use of renewable primary energy excluding renewable primary energy resources used as raw materials; PERM = Use of renewable primary energy resources used as raw materials; PERT = Total use of renewable primary energy resources; PENRE = Use of non renewable primary energy excluding non renewable primary energy resources used as raw materials; PENRM = Use of non renewable primary energy resources used as raw materials; PENRT = Total use of non renewable primary energy resources; SM = Use of secondary material; RSF = Use of renewable secondary fuels; NRSF = Use of non renewable secondary fuels; FW = Net use of fresh water						

WASTE CATEGORIES AND OUTPUT FLOWS PER 1 TONNE OF FAÇADE TILE

Parameter	Unit	A1-A3	C1	C2	C3	C4	D
HWD	[kg]	4.75E-05	0.00E+00	2.92E-06	3.86E-09	9.10E-08	-2.49E-07
NHWD	[kg]	1.98E+00	0.00E+00	1.00E-02	8.08E-03	3.00E+01	-1.81E+01
RWD	[kg]	1.94E-02	0.00E+00	1.17E-04	1.36E-04	6.78E-05	-9.21E-04
CRU	[kg]	0.00E+00	0.00E+00	0.00E+00	0.00E+00	0.00E+00	0.00E+00
MFR	[kg]	6.10E+01	0.00E+00	0.00E+00	9.70E+02	0.00E+00	0.00E+00
MER	[kg]	0.00E+00	0.00E+00	0.00E+00	0.00E+00	0.00E+00	0.00E+00
EE	[MJ]	0.00E+00	0.00E+00	0.00E+00	0.00E+00	0.00E+00	0.00E+00
Caption	HWD = Hazardous waste disposed; NHWD = Non hazardous waste disposed; RWD = Radioactive waste disposed; CRU = Components for re-use; MFR = Materials for recycling; MER = Materials for energy recovery; EE = Exported energy						

BIOGENIC CARBON CONTENT PER 1 TONNE OF FAÇADE TILE

Parameter	Unit	At the factory gate
Biogenic carbon content in product	[kg C]	0.00E+00
Biogenic carbon content in accompanying packaging	[kg C]	1.36E+00
Note	1 kg biogenic carbon is equivalent to 44/12 kg of CO ₂	

Group 1: Beach Yellow + Nordic Red + Terracotta Red

ENVIRONMENTAL IMPACTS PER 1 TONNE OF FAÇADE TILE							
Parameter	Unit	A1-A3	C1	C2	C3	C4	D
GWP-total	[kg CO ₂ eq.]	2.24E+02	0.00E+00	4.75E+00	2.34E-01	4.20E-01	-9.01E-01
GWP-fossil	[kg CO ₂ eq.]	2.28E+02	0.00E+00	4.66E+00	2.36E-01	4.55E-01	-9.29E-01
GWP-biogenic	[kg CO ₂ eq.]	-4.22E+00	0.00E+00	5.07E-02	-2.40E-03	-3.61E-02	3.21E-02
GWP-luluc	[kg CO ₂ eq.]	4.05E-01	0.00E+00	3.82E-02	4.48E-04	1.31E-03	-4.45E-03
ODP	[kg CFC 11 eq.]	7.82E-07	0.00E+00	8.66E-16	1.05E-09	1.69E-15	-8.24E-15
AP	[mol H ⁺ eq.]	2.70E-01	0.00E+00	5.45E-03	3.94E-04	3.26E-03	-6.42E-03
EP-freshwater	[kg PO ₄ eq.]	3.44E-03	0.00E+00	1.44E-05	6.93E-06	7.81E-07	-3.90E-06
EP-marine	[kg N eq.]	8.05E-02	0.00E+00	1.68E-03	1.21E-04	8.40E-04	-2.53E-03
EP-terrestrial	[mol N eq.]	9.22E-01	0.00E+00	1.99E-02	1.22E-03	9.23E-03	-2.79E-02
POCP	[kg NMVOC eq.]	2.54E-01	0.00E+00	4.52E-03	3.38E-04	2.54E-03	-7.28E-03
ADPm ¹	[kg Sb eq.]	1.32E-03	0.00E+00	3.82E-07	2.40E-07	4.09E-08	-1.58E-07
ADPf ¹	[MJ]	3.46E+03	0.00E+00	6.30E+01	2.68E+00	5.97E+00	-1.37E+01
WDP ¹	[m ³]	2.04E+01	0.00E+00	4.60E-02	1.69E-02	4.77E-02	-1.03E-01
Caption	GWP-total = Global Warming Potential - total; GWP-fossil = Global Warming Potential - fossil fuels; GWP-biogenic = Global Warming Potential - biogenic; GWP-luluc = Global Warming Potential - land use and land use change; ODP = Ozone Depletion; AP = Acidification; EP-freshwater = Eutrophication – aquatic freshwater; EP-marine = Eutrophication – aquatic marine; EP-terrestrial = Eutrophication – terrestrial; POCP = Photochemical zone formation; ADPm = Abiotic Depletion Potential – minerals and metals; ADPf = Abiotic Depletion Potential – fossil fuels; WDP = water use						
Disclaimer	¹ The results of this environmental indicator shall be used with care as the uncertainties on these results are high or as there is limited experienced with the indicator.						

ADDITIONAL ENVIRONMENTAL IMPACTS PER 1 TONNE OF FAÇADE TILE							
Parameter	Unit	A1-A3	C1	C2	C3	C4	D
PM	[Disease incidence]	3.58E-06	0.00E+00	3.62E-08	4.33E-09	4.04E-08	-3.08E-07
IRP ²	[kBq U235 eq.]	3.84E+00	0.00E+00	1.72E-02	1.51E-02	6.97E-03	-1.48E-01
ETP-fw ¹	[CTUe]	9.56E+02	0.00E+00	4.71E+01	1.23E+00	3.41E+00	-7.60E+00
HTP-c ¹	[CTUh]	5.21E-08	0.00E+00	9.74E-10	1.89E-10	5.05E-10	-5.64E-10
HTP-nc ¹	[CTUh]	1.81E-06	0.00E+00	4.97E-08	4.09E-09	5.57E-08	-5.74E-08
SQP ¹	-	1.55E+03	0.00E+00	2.21E+01	2.76E+00	1.24E+00	-3.74E+00
Caption	PM = Particulate Matter emissions; IRP = Ionizing radiation – human health; ETP-fw = Eco toxicity – freshwater; HTP-c = Human toxicity – cancer effects; HTP-nc = Human toxicity – non cancer effects; SQP = Soil Quality (dimensionless)						
Disclaimers	¹ The results of this environmental indicator shall be used with care as the uncertainties on these results are high or as there is limited experienced with the indicator.						
	² This impact category deals mainly with the eventual impact of low dose ionizing radiation on human health of the nuclear fuel cycle. It does not consider effects due to possible nuclear accidents, occupational exposure nor due to radioactive waste disposal in underground facilities. Potential ionizing radiation from the soil, from radon and from some construction materials is also not measured by this indicator.						

RESOURCE USE PER 1 TONNE OF FAÇADE TILE							
Parameter	Unit	A1-A3	C1	C2	C3	C4	D
PERE	[MJ]	3.58E+02	0.00E+00	3.64E+00	3.78E+00	7.82E-01	-3.41E+00
PERM	[MJ]	4.80E+01	0.00E+00	0.00E+00	0.00E+00	0.00E+00	0.00E+00
PERT	[MJ]	4.06E+02	0.00E+00	3.64E+00	3.78E+00	7.82E-01	-3.41E+00
PENRE	[MJ]	3.44E+03	0.00E+00	6.32E+01	2.68E+00	5.97E+00	-1.37E+01
PENRM	[MJ]	1.34E+01	0.00E+00	0.00E+00	0.00E+00	0.00E+00	0.00E+00
PENRT	[MJ]	3.46E+03	0.00E+00	6.32E+01	2.68E+00	5.97E+00	-1.37E+01
SM	[kg]	1.42E+02	0.00E+00	0.00E+00	0.00E+00	0.00E+00	0.00E+00
RSF	[MJ]	0.00E+00	0.00E+00	0.00E+00	0.00E+00	0.00E+00	0.00E+00
NRSF	[MJ]	0.00E+00	0.00E+00	0.00E+00	0.00E+00	0.00E+00	0.00E+00
FW	[m ³]	6.91E-01	0.00E+00	4.24E-03	1.75E-03	1.51E-03	-4.20E-03
Caption	PERE = Use of renewable primary energy excluding renewable primary energy resources used as raw materials; PERM = Use of renewable primary energy resources used as raw materials; PERT = Total use of renewable primary energy resources; PENRE = Use of non renewable primary energy excluding non renewable primary energy resources used as raw materials; PENRM = Use of non renewable primary energy resources used as raw materials; PENRT = Total use of non renewable primary energy resources; SM = Use of secondary material; RSF = Use of renewable secondary fuels; NRSF = Use of non renewable secondary fuels; FW = Net use of fresh water						

WASTE CATEGORIES AND OUTPUT FLOWS PER 1 TONNE OF FAÇADE TILE							
Parameter	Unit	A1-A3	C1	C2	C3	C4	D
HWD	[kg]	4.59E-05*	0.00E+00	2.92E-06	3.86E-09	9.10E-08	-2.48E-07
NHWD	[kg]	3.38E+00**	0.00E+00	1.00E-02	8.08E-03	3.00E+01	-1.80E+01
RWD	[kg]	1.93E-02	0.00E+00	1.17E-04	1.36E-04	6.78E-05	-9.17E-04

CRU	[kg]	0.00E+00	0.00E+00	0.00E+00	0.00E+00	0.00E+00	0.00E+00
MFR	[kg]	6.10E+01	0.00E+00	0.00E+00	9.70E+02	0.00E+00	0.00E+00
MER	[kg]	0.00E+00	0.00E+00	0.00E+00	0.00E+00	0.00E+00	0.00E+00
EE	[MJ]	0.00E+00	0.00E+00	0.00E+00	0.00E+00	0.00E+00	0.00E+00
Caption	HWD = Hazardous waste disposed; NHWD = Non hazardous waste disposed; RWD = Radioactive waste disposed; CRU = Components for re-use; MFR = Materials for recycling; MER = Materials for energy recovery; EE = Exported energy						

* This indicator varies 59% between highest and lowest impact in the product group. Thus, the highest impact from Product 3 is stated. The difference is caused by the amount of input of dry clay powder and clay in the Engobe.

** This indicator varies 14% between highest and lowest impact in the product group. Thus, the highest impact from Product 4 is stated. The difference is caused by the amount of input of sand.

BIOGENIC CARBON CONTENT PER 1 TONNE OF FAÇADE TILE		
Parameter	Unit	At the factory gate
Biogenic carbon content in product	[kg C]	0.00E+00
Biogenic carbon content in accompanying packaging	[kg C]	1.36E+00
Note	1 kg biogenic carbon is equivalent to 44/12 kg of CO ₂	

Group 2: Brazilian Brown + Cloudy Gray + Concrete Gray

ENVIRONMENTAL IMPACTS PER 1 TONNE OF FAÇADE TILE							
Parameter	Unit	A1-A3	C1	C2	C3	C4	D
GWP-total	[kg CO ₂ eq.]	3.61E+02	0.00E+00	4.75E+00	2.34E-01	4.20E-01	-9.05E-01
GWP-fossil	[kg CO ₂ eq.]	3.63E+02	0.00E+00	4.66E+00	2.36E-01	4.55E-01	-9.33E-01
GWP-biogenic	[kg CO ₂ eq.]	-3.03E+00	0.00E+00	5.07E-02	-2.40E-03	-3.61E-02	3.22E-02
GWP-luluc	[kg CO ₂ eq.]	5.85E-01	0.00E+00	3.82E-02	4.48E-04	1.31E-03	-4.47E-03
ODP	[kg CFC 11 eq.]	1.10E-05	0.00E+00	8.66E-16	1.05E-09	1.69E-15	-8.28E-15
AP	[mol H ⁺ eq.]	1.18E+00	0.00E+00	5.45E-03	3.94E-04	3.26E-03	-6.45E-03
EP-freshwater	[kg PO ₄ eq.]	7.26E-02	0.00E+00	1.44E-05	6.93E-06	7.81E-07	-3.92E-06
EP-marine	[kg N eq.]	2.15E-01	0.00E+00	1.68E-03	1.21E-04	8.40E-04	-2.54E-03
EP-terrestrial	[mol N eq.]	2.35E+00	0.00E+00	1.99E-02	1.22E-03	9.23E-03	-2.80E-02
POCP	[kg NMVOC eq.]	6.43E-01	0.00E+00	4.52E-03	3.38E-04	2.54E-03	-7.31E-03
ADPm ¹	[kg Sb eq.]	1.60E-02	0.00E+00	3.82E-07	2.40E-07	4.09E-08	-1.59E-07
ADPf ¹	[MJ]	5.52E+03	0.00E+00	6.30E+01	2.68E+00	5.97E+00	-1.37E+01
WDP ¹	[m ³]	1.79E+02	0.00E+00	4.60E-02	1.69E-02	4.77E-02	-1.03E-01
Caption	GWP-total = Global Warming Potential - total; GWP-fossil = Global Warming Potential - fossil fuels; GWP-biogenic = Global Warming Potential - biogenic; GWP-luluc = Global Warming Potential - land use and land use change; ODP = Ozone Depletion; AP = Acidification; EP-freshwater = Eutrophication – aquatic freshwater; EP-marine = Eutrophication – aquatic marine; EP-terrestrial = Eutrophication – terrestrial; POCP = Photochemical zone formation; ADPm = Abiotic Depletion Potential – minerals and metals; ADPf = Abiotic Depletion Potential – fossil fuels; WDP = water use						
Disclaimer	¹ The results of this environmental indicator shall be used with care as the uncertainties on these results are high or as there is limited experienced with the indicator.						

ADDITIONAL ENVIRONMENTAL IMPACTS PER 1 TONNE OF FAÇADE TILE							
Parameter	Unit	A1-A3	C1	C2	C3	C4	D
PM	[Disease incidence]	8.50E-06	0.00E+00	3.62E-08	4.33E-09	4.04E-08	-3.09E-07
IRP ²	[kBq U235 eq.]	3.56E+01	0.00E+00	1.72E-02	1.51E-02	6.97E-03	-1.49E-01
ETP-fw ¹	[CTUe]	1.32E+04	0.00E+00	4.71E+01	1.23E+00	3.41E+00	-7.64E+00
HTP-c ¹	[CTUh]	1.12E-07	0.00E+00	9.74E-10	1.89E-10	5.05E-10	-5.66E-10
HTP-nc ¹	[CTUh]	4.63E-06	0.00E+00	4.97E-08	4.09E-09	5.57E-08	-5.77E-08
SQP ¹	-	2.35E+03	0.00E+00	2.21E+01	2.76E+00	1.24E+00	-3.75E+00
Caption	PM = Particulate Matter emissions; IRP = Ionizing radiation – human health; ETP-fw = Eco toxicity – freshwater; HTP-c = Human toxicity – cancer effects; HTP-nc = Human toxicity – non cancer effects; SQP = Soil Quality (dimensionless)						
Disclaimers	¹ The results of this environmental indicator shall be used with care as the uncertainties on these results are high or as there is limited experienced with the indicator.						
	² This impact category deals mainly with the eventual impact of low dose ionizing radiation on human health of the nuclear fuel cycle. It does not consider effects due to possible nuclear accidents, occupational exposure nor due to radioactive waste disposal in underground facilities. Potential ionizing radiation from the soil, from radon and from some construction materials is also not measured by this indicator.						

RESOURCE USE PER 1 TONNE OF FAÇADE TILE							
Parameter	Unit	A1-A3	C1	C2	C3	C4	D
PERE	[MJ]	5.86E+02	0.00E+00	3.64E+00	3.78E+00	7.82E-01	-3.43E+00
PERM	[MJ]	4.80E+01	0.00E+00	0.00E+00	0.00E+00	0.00E+00	0.00E+00
PERT	[MJ]	6.34E+02	0.00E+00	3.64E+00	3.78E+00	7.82E-01	-3.43E+00
PENRE	[MJ]	5.51E+03	0.00E+00	6.32E+01	2.68E+00	5.97E+00	-1.37E+01
PENRM	[MJ]	1.34E+01	0.00E+00	0.00E+00	0.00E+00	0.00E+00	0.00E+00
PENRT	[MJ]	5.52E+03	0.00E+00	6.32E+01	2.68E+00	5.97E+00	-1.37E+01
SM	[kg]	1.37E+02	0.00E+00	0.00E+00	0.00E+00	0.00E+00	0.00E+00
RSF	[MJ]	0.00E+00	0.00E+00	0.00E+00	0.00E+00	0.00E+00	0.00E+00
NRSF	[MJ]	0.00E+00	0.00E+00	0.00E+00	0.00E+00	0.00E+00	0.00E+00
FW	[m ³]	4.39E+00	0.00E+00	4.24E-03	1.75E-03	1.51E-03	-4.22E-03
Caption	PERE = Use of renewable primary energy excluding renewable primary energy resources used as raw materials; PERM = Use of renewable primary energy resources used as raw materials; PERT = Total use of renewable primary energy resources; PENRE = Use of non renewable primary energy excluding non renewable primary energy resources used as raw materials; PENRM = Use of non renewable primary energy resources used as raw materials; PENRT = Total use of non renewable primary energy resources; SM = Use of secondary material; RSF = Use of renewable secondary fuels; NRSF = Use of non renewable secondary fuels; FW = Net use of fresh water						

WASTE CATEGORIES AND OUTPUT FLOWS PER 1 TONNE OF FAÇADE TILE							
Parameter	Unit	A1-A3	C1	C2	C3	C4	D
HWD	[kg]	3.83E-05*	0.00E+00	2.92E-06	3.86E-09	9.10E-08	-2.49E-07
NHWD	[kg]	2.83E+00	0.00E+00	1.00E-02	8.08E-03	3.00E+01	-1.81E+01
RWD	[kg]	1.93E-02	0.00E+00	1.17E-04	1.36E-04	6.78E-05	-9.21E-04

CRU	[kg]	0.00E+00	0.00E+00	0.00E+00	0.00E+00	0.00E+00	0.00E+00
MFR	[kg]	6.10E+01	0.00E+00	0.00E+00	9.70E+02	0.00E+00	0.00E+00
MER	[kg]	0.00E+00	0.00E+00	0.00E+00	0.00E+00	0.00E+00	0.00E+00
EE	[MJ]	0.00E+00	0.00E+00	0.00E+00	0.00E+00	0.00E+00	0.00E+00
Caption	HWD = Hazardous waste disposed; NHWD = Non hazardous waste disposed; RWD = Radioactive waste disposed; CRU = Components for re-use; MFR = Materials for recycling; MER = Materials for energy recovery; EE = Exported energy						

* This indicator varies 39% between highest and lowest impact in the product group. Thus, the highest impact from Product 7 is stated. The difference is caused by the amount of input of dry clay powder and clay in the Engobe.

BIOGENIC CARBON CONTENT PER 1 TONNE OF FAÇADE TILE		
Parameter	Unit	At the factory gate
Biogenic carbon content in product	[kg C]	0.00E+00
Biogenic carbon content in accompanying packaging	[kg C]	1.36E+00
Note	1 kg biogenic carbon is equivalent to 44/12 kg of CO ₂	

Additional information

Technical information on scenarios

Transport to the building site (A4)

Scenario information	Value	Unit
Not relevant		

Installation of the product in the building (A5)

Scenario information	Value	Unit
Packaging material (EU pallet) – 10% virgin material and 90% secondary material (includes nails and wood)	31.25	kg
Packaging material (plastic wrap)	0.31	kg

Reference service life

RSL information	Unit
Reference service Life (based on the reference PCR)	150 years

Use (B1-B7)

Scenario information	Value	Unit
Not relevant		

End of life (C1-C4)

Scenario information	Value	Unit
Collected separately	1000	kg
Collected with mixed waste	0	kg
For reuse	0	kg
For recycling	970	kg
For energy recovery	0	kg
For final disposal (landfilling)	30	kg

Re-use, recovery and recycling potential (D)

Scenario information/Materiel	Value	Unit
Crushed bricks replaced as gravel	432-434	kg

Indoor air

The EPD does not give information on release of dangerous substances to indoor air because the horizontal standards on measurement of release of regulated dangerous substances from construction products using harmonised test methods according to the provisions of the respective technical committees for European product standards are not available.

Soil and water

The EPD does not give information on release of dangerous substances to soil and water because the horizontal standards on measurement of release of regulated dangerous substances from construction products using harmonised test methods according to the provisions of the respective technical committees for European product standards are not available.

References

Publisher	 epddanmark www.epddanmark.dk
Programme operator	Danish Technological Institute Buildings & Environment Gregersensvej DK-2630 Taastrup www.teknologisk.dk
LCA-practitioner	Nana Lin Rasmussen and Lise Hvid Horup Sørensen Rambøll A/S Hannemanns Allé 53 DK-2300 København S Denmark E-mail: nlra@ramboll.dk
LCA software / background data	GaBi (version 9.2) Generic data are primarily based on life cycle inventory data from GaBi Professional Database 2020 and Ecoinvent version 3.6.
3rd party verifier	Charlotte Merlin, FORCE Technology Danmark

General programme instructions

Version 2.0, www.epddanmark.dk

EN 15804

DS/EN 15804 + A2:2019 - "Sustainability of construction works – Environmental product declarations – Core rules for the product category of construction products"

TBE PCR

Product Category Rules for Environmental Product Declarations for Construction Clay Products, Tiles and Bricks Europe, 2020

EN 15942

DS/EN 15942:2011 – " Sustainability of construction works – Environmental product declarations – Communication format business-to-business"

ISO 14025

DS/EN ISO 14025:2010 – " Environmental labels and declarations – Type III environmental declarations – Principles and procedures"

ISO 14040

DS/EN ISO 14040:2008 – " Environmental management – Life cycle assessment – Principles and framework"

ISO 14044

DS/EN ISO 14044:2008 – " Environmental management – Life cycle assessment – Requirements and guidelines"

Miljøstyrelsen. (2003). Miljøprojekt nr. 804, 2003 - Ressourcebesparelser ved affaldsbehandlingen i Danmark. Retrieved from 6. Tegl: <https://www2.mst.dk/udgiv/publikationer/2003/87-7972-603-8/html/bilag01/kap06.htm>